

StowAway2

Cargo Carriers

StowAway2 Swingaway Bike Racks Assembly Instructions Rev. 0307 Models 025.6 and 025.7

Please review the instructions and warranty carefully before assembling the unit.

Assembly and installation of the StowAway2 Swingaway Bike Rack and/or Cargo Rack are the end user's responsibility and beyond Pacific Recreational Product's control. PRP limits its warranty to the repair or replacement of a defective product for up to five years from date of retail purchase. Damage to your vehicle, cargo, or to any person or property is excluded. Please see page four for more detailed information regarding PRP's warranty.

Safety Guidelines when using the StowAway2 Swingaway Bike and/or Cargo Rack:

- **Always secure your bikes with a secondary safety strap and/or cable lock (items not included)!** There is a D-Ring on the Bike Rack's post that serves as an attachment point for a strap or cable.
- 2" hitch models should be used with Class III (or greater) 2" receiver hitches only. Do not exceed the rated tongue weight of the receiver hitch or the vehicle. Do not exceed the gross vehicle weight at any time. The rack is not intended for off-road use.
- The maximum capacity of the Bike Rack is four (4) bikes.
- The maximum capacity of the Bike/Cargo Rack combination is four (4) bikes and gear up to a total weight of 200 pounds.
- For safety to your vehicle and rack system, always obey posted speed limits and traffic cautions. Adapt your speed to the conditions of the road, the load being carried, and the overall vehicle length with the rack installed.
- Always use caution when swinging the rack away from your vehicle.
- Do not step on the Swingaway frame or place additional weight on rack when in the open position.
- Do not allow people to climb on the bike rack at any time.
- To inhibit rust and corrosion, rinse and lubricate your bike rack after each use. If the rack is exposed to road salt it is recommended that an extra rust inhibitor be applied to any exposed area after cleaning and drying the rack.

Before driving with the Swingaway Bike Rack installed, please:

- Make sure all knobs, bolts, screws, and locks are firmly attached, tightened and locked before every trip. Knobs, bolts, screws and locks must be periodically inspected for signs of wear, corrosion, and/or fatigue.
- Make sure the Swingaway frame is fully closed and latched before moving the vehicle. Ensure that both safety pins are engaged.

Carton Contains

- 1 ea- Bike Rack Post (bottom section)
Incl. D-ring & 3 bolt sets
- 1 ea- Bike Cradle Assembly (top section)
Incl. 1 bolt set
- 8 ea- Bike Cradles with straps
- 1 ea- Swingaway frame (if ordered)
- 1 ea- Cargo Rack (if ordered)

Tools Required

- 7/16" Adjustable Wrench

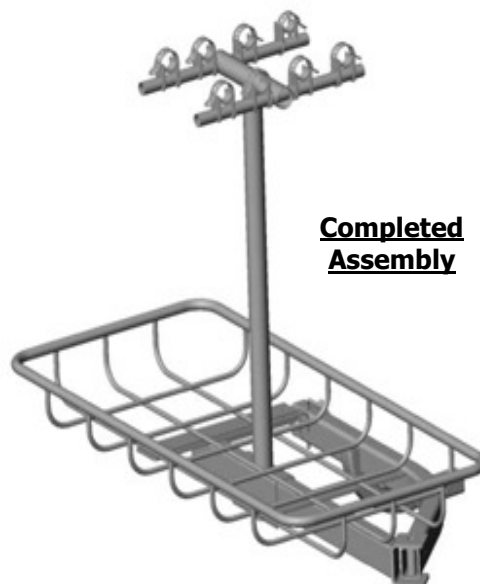

Order of Assembly

1. Assembling the Swingaway Frame
2. Attaching the Bike Rack Post
3. Assembling the Cargo Rack (if ordered)
4. Attaching the Cargo Rack (if ordered)
5. Attaching the Bike Cradle Assembly

StowAway²

Cargo Carriers

Assembling the StowAway² Swingaway Frame (BR Models 025.6, 025.7)

Remove parts from cartons and confirm that all parts have been received. Save all packaging until the unit is fully assembled and functional. Contact us at (800) 943-5377 if any parts are not received.

Swingaway Frame

1 ea- Swing Arm

1 ea- Hitch bar

Hardware Kit

1 ea- 3/4" Pivot Bolt

3 ea- 3/4" Flat Washers

1 ea- 3/4" Lock Nut

1 ea- Hitch Pin

1 ea- Hitch-Coupling Tightener

4 ea- 3/8" Bolts

4 ea- Oval Washers

4 ea- 3/8" Lock Nuts

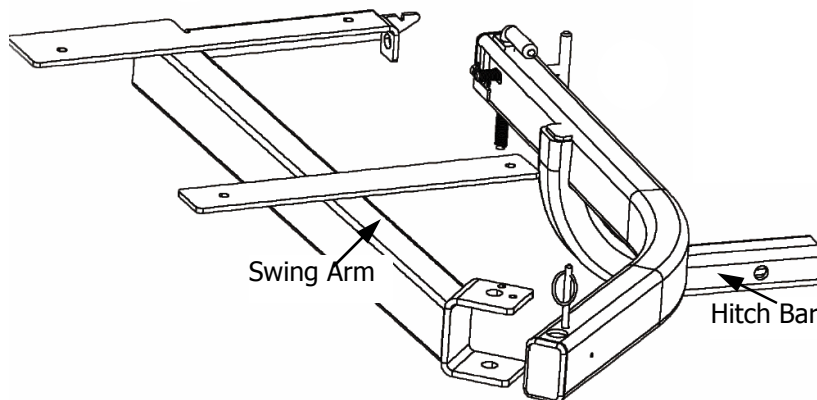

Tools Required for Assembly

Two large adjustable end wrenches or socket wrenches with sockets up to 1-1/8" span.

1. Assembling the Swingaway frame (ignore this step if the frame has already been assembled)

- Place hitch bar into vehicle's 2" receiver hitch, aligning hitch pin holes. **See Fig 1.** Locate the hitch pin from the hardware kit and install it into the hitch. It is not necessary to install the Hitch-Coupling Tightener at this point unless you plan on using your frame immediately.
- Fit the swing arm yoke over the point of rotation on the hitch bar. **See Fig 2.** Insert two 3/4" flat washers between the yoke and the hitch bar. **See Fig 3.** **This is important, as the washers are the bearing surfaces that the swing arm pivots on for smooth operation.** Next, push the 3/4" pivot bolt through the aligned yoke and hitch bar hole. Before threading on the 3/4" nylon lock nut, put the third 3/4" flat washer on the pivot bolt (the washer should be between the yoke and the nut). **This is important to ensure adequate threads on the pivot bolt for proper tightening.** Tighten the nylon lock nut onto the pivot bolt until the swing arm swings freely, yet with some resistance. **The nut must be tightened snugly to the bottom of the yoke.**
- Test the frame to ensure that the frame swings freely.

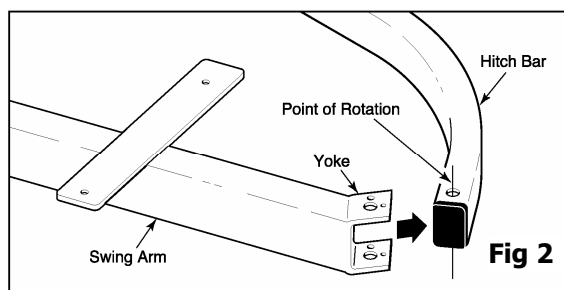
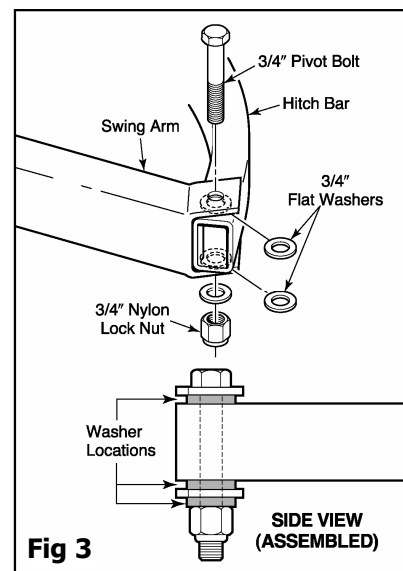
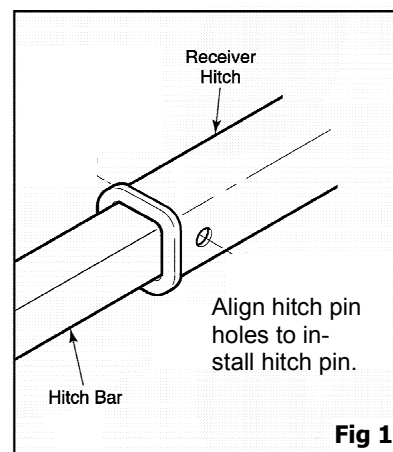

StowAway² Cargo Carriers

2. Attaching the Bike Rack Post to the Swingaway Frame

- Slide the bike rack post over the swing arm of the Swingaway frame, centering it between the two horizontal crossmembers. Bolt the post into place with the bolts, washers and locknuts provided. Do not tighten if you will also be mounting the cargo rack, otherwise tighten fully.

3. Assembling the Cargo Rack (if ordered)

- On a smooth surface, orient the left and right sides of the cargo rack **in an upside-down position**. Push the two halves of the cargo rack together by carefully sliding the tubing of the right side inside the tubing of the left side. (See illustration A).
- Once the two halves are together, slight adjustment may be needed to line up the screw holes. (See illustration B).
- After the screw holes are lined up, use a Phillips screwdriver and two of the supplied screws to tighten the two halves together. Tighten firmly.
- Turn the cargo rack right-side up. Orient the left and right sides to fit the "rear" of the cargo rack. The "rear" of the cargo rack has two small holes for mounting the nameplate on the perimeter tube (See illustration C). On the "front" side of the cargo rack, install another screw on the top of the perimeter tubing to secure the two halves together. Move to the "rear" tube and install the StowAway² nameplate with the two screws provided. Tighten all screws firmly.

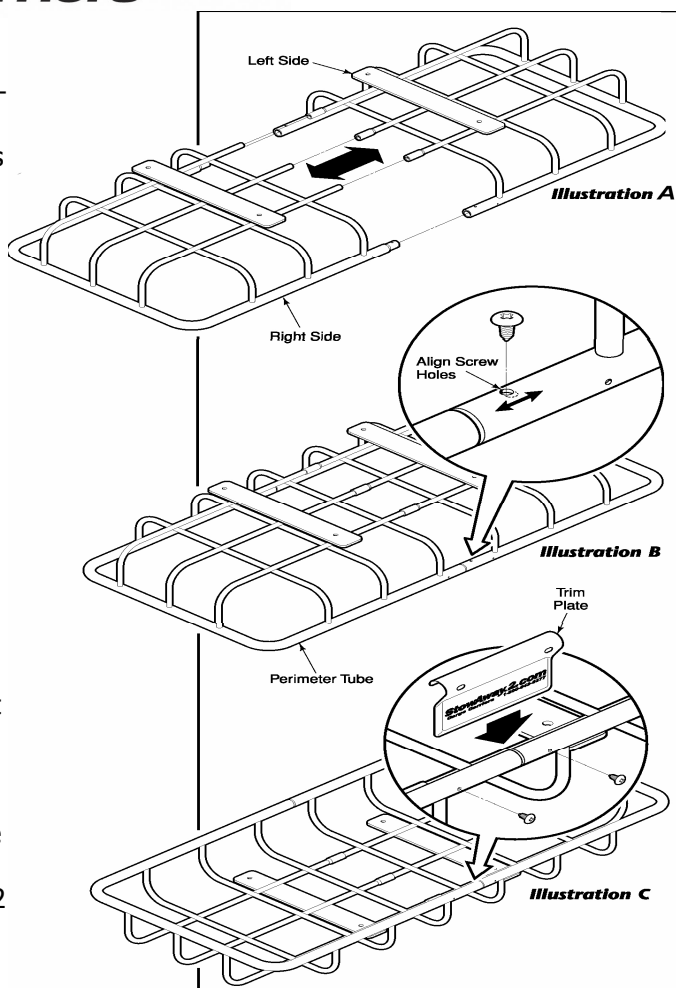

4. Attaching the Cargo Rack to Swingaway Frame (if ordered)

- **The Cargo Rack should be installed after the Bike Rack Post is positioned on the swing arm as described in No. 2 above.**
- Slide the Cargo Rack over the Bike Rack Post (See illustration D) being sure to align the rack mounting holes with the mounting holes on the frame.
- Bolt the Cargo Rack to the Swingaway frame using the four bolts, washers and locking nuts provided (bolts and washers on the top side). Tighten firmly.
- Confirm that the Bike Rack Post is centered on the frame swing arm and tighten bolts holding post in place.

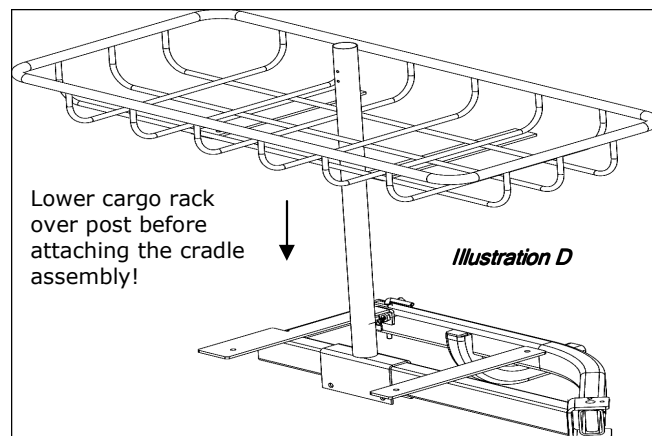

5. Attaching the Bike Cradle Assembly (Top Section)

- Slide the Cradle Assembly over the Post and align the bolt holes. The Cradle Assembly should be positioned so that the bikes run parallel to the back of the vehicle. Insert the bolt through the alignment hole with the D ring facing the rear. Fasten in place with the lock nut. If necessary, it is possible to rotate the bike cradle assembly by removing the bolt.
- Adjust the location of your cradles (if desired) and tighten mounting screws.
- Load bikes onto the bike cradles and fasten with the cradle straps. **Always use a safety strap or security cable when fastening bikes to the rack: the D-ring acts as an attachment point for your strap or cable.**

StowAway2

Cargo Carriers

Using the StowAway2 Bike Rack Systems

Always use the appropriate hitch pin when driving with a StowAway2 Bike Rack.

To latch the Swingaway frame, swing the rack or carrier firmly toward the vehicle until the plunger pin has latched the swing arm and is fully engaged. (effort required to close may increase as more weight is loaded onto the rack or carrier). Next, screw the T-bolt safety into the swing arm nut until the T-bolt washer is flush against the frame. Be careful to keep the threads properly aligned to prevent cross threading. Finally, drop the secondary safety pin into place near the pivot bolt. If you are not able to engage the safeties it is likely that the frame is not fully engaged. **Always use both safeties when driving with the StowAway2 Bike Rack.** (See Fig 1.)

Always ensure that the Swingaway frame is properly latched and that both safeties are fully engaged before moving the vehicle.

To swing the rack away from the vehicle, first remove the secondary safety pin near the pivot bolt (See Fig 2). Next, unscrew the primary safety T-bolt until the threads are free of the swing arm. Finally, pull up on the plunger pin handle while manually swinging the bike rack away from the vehicle.

When the Swingaway frame is open 90 degrees, the secondary safety pin may be re-installed to "lock" the unit in position.

Care should be taken when swinging the bike rack out near traffic or on an incline. It is best to load the bike rack in the closed position to prevent unwanted rack movement when loading.

Warranty on all StowAway2 Racks and Carriers

Pacific Recreational Products, Inc. warrants to the original retail purchaser of this StowAway2 cargo carrier or rack that it is and shall remain free of defects in materials and workmanship for a period of five years from the date of retail purchase.

Should the purchaser discover a defect and notify PRP during the warranty period, PRP will, at its option, repair or replace the unit at no additional charge, or refund all or part of the customer's original purchase price. The limited warranty does not cover damages caused by collision, disaster, abuse, modification, misuse or normal wear and tear. Misuse includes but is not limited to overloading of the carrier, exceeding the vehicle's or hitch receiver's load capacities, improper installation, off-road use, use with a hitch of an incorrect size and style, or rust/corrosion caused by lack of care.

Limited warranty services may be obtained by first calling, emailing or writing to PRP and describing the problem or perceived defect. PRP may request documentation to fully understand the nature of the problem or defect. If a defect or problem is confirmed, PRP will, at its sole discretion, replace, repair, or authorize the return of the cargo carrier or rack to PRP for a full or partial refund. Returns must be made to the specified address, along with the proof of purchase date, using the original shipping container or equivalent. Unless otherwise authorized, return transportation charges must be prepaid by the purchaser.

All express and implied warranties for this product, including the warranties of merchantability and fitness for a particular purpose, are limited in duration to a period of five years from the date of purchase and no warranties, whether expressed or implied, will apply after this period.

If this product is defective, the sole remedy shall be repair, replacement or refund as provided above. In no event will PRP or any of its officers, employees, or agents be liable to the purchaser for any damages, including incidental or consequential damages arising out of the use of or inability to use the cargo carrier or rack system, even if PRP has been advised of the possibility of such damages, or for any claim by another party.

Pacific Recreational Products, Inc.
7291 SW Tech Center Dr • Tigard, OR 97223
Phone: **1.800.943.5377** • Fax: **503.968.1433**

www.stowaway2.com
E-mail: info@stowaway2.com

Thank you for choosing StowAway2!

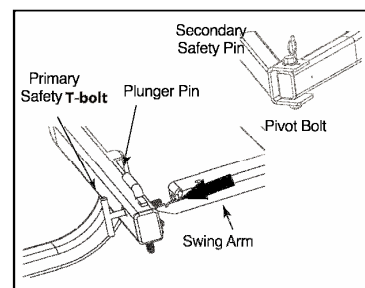

FIG 1.

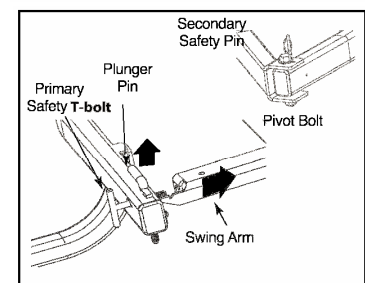

FIG 2.

